

THE APOLLO

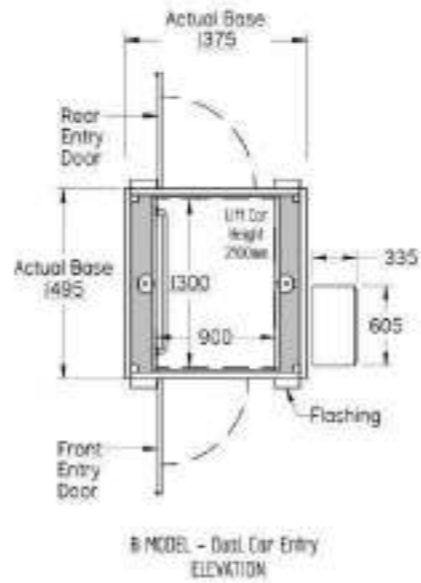

RESIDENTIAL

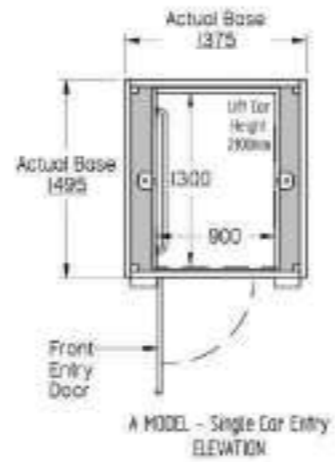
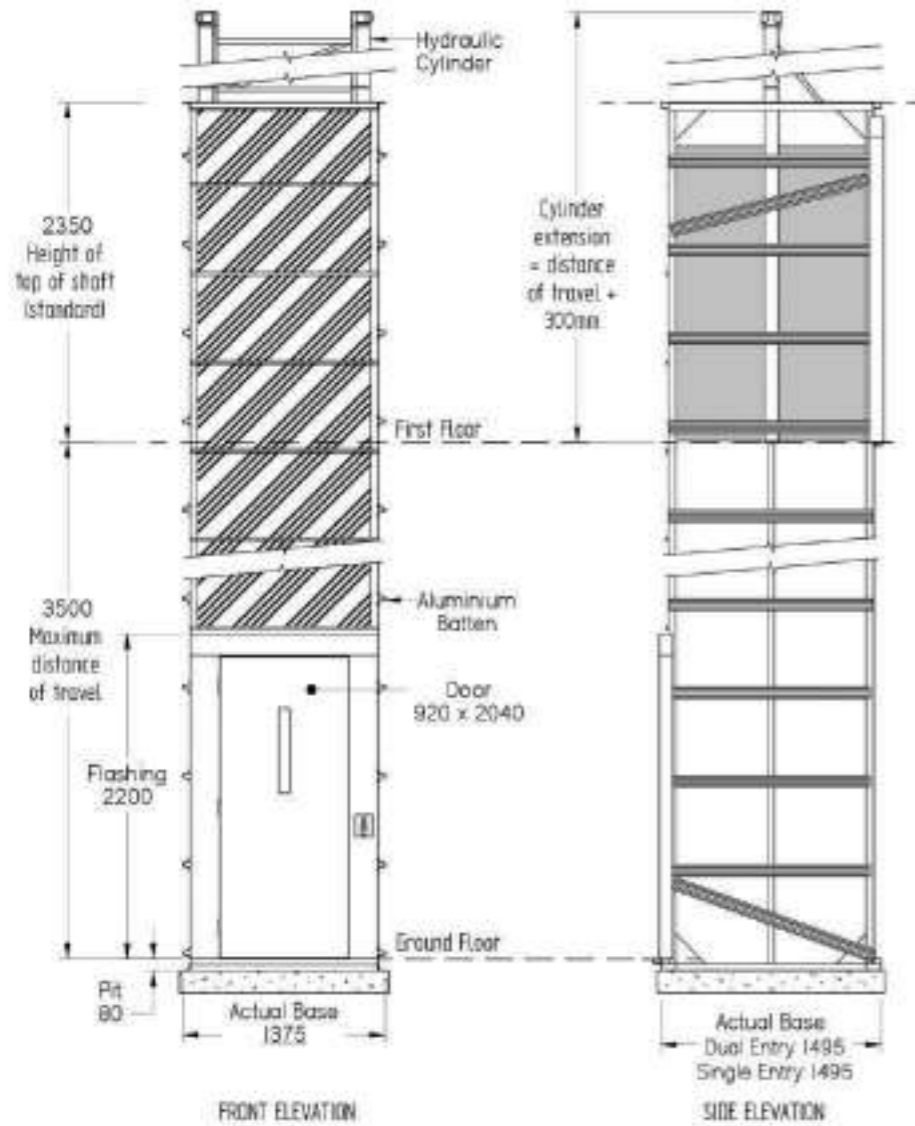

DISABLED USE

THE APOLLO

NOT FOR CONSTRUCTION

MAIN SPECIFICATIONS

- Carrying Capacity:** 250kg
- Car Size:** 900W x 1300D x 2100Hmm
- Door Size:** 920W x 2040Hmm
- Maximum Travel:** 3500mm
- Lift Speed:** 0.093m/sec with a 90kg load
- Max No. of Stops:** 2 Stops
- Drive System:** Water hydraulic with direct acting cylinders on each side of the lift car
- Minimum Pit Depth:** 80mm
- Cylinder Extension:** Distance of travel plus 300mm
- Machine Cabinet:** 605W x 335D x 1800Hmm
- Controls:** Automatic operation & key isolation
- Standards:** Meets or exceeds requirements of the Australian Standards Lift code AS1735 Part 17
- Usage:** Residential
- Application:** Internal or external
- Installation:** Crane in, dismantle or manoeuvred
- Lift Tower:** Inclusive. Self supporting - no structural walls required. Cladding by others can be attached directly to the lift structure
- Supply Voltage:** 240volt. Single Phase. 20amp RCD protected

 **1800 AUS LIFT**
1800 287 5438

Call Us - We're Here to Help

We have an unrivalled reputation for after-sales care and customer service. Call us and one of our friendly lift specialists will gladly answer all your questions.

Aussie Lifts Pty Ltd
12 Achievement Crescent
Acacia Ridge QLD 4110
Tel (07) 3274 4211
info@aussielifts.com.au
www.aussielifts.com.au
A.B.N # 90 618 522 277

AUSSIE LIFTS

AUSSIE LIFTS

Water Hydraulic Residential Lift



“Perfect for new construction or retrofitting, the Apollo can easily be incorporated into a two level home for independent living.”

Originating from the basic concept of using water to hoist a platform, the Apollo has evolved into a lift that is purposely built for disable use.

Custom built, special consideration can be made with the operation of the lift through different style buttons, automatic dialling telephone and door operators.

Able to travel 3.5 metres, the Apollo has the capacity to carry 250kg easily.

Offering flexibility for tight spaces, the size of the lift can be reduced by altering the lift's structure. The self supporting lift tower also means cladding can be attached directly to the lift's frame.

To help compliment the decor of your home, the Apollo has a number of cosmetic options available when it comes to landing doors and the lift car lining.

In addition, the lift is jam packed with an array of safety features and is a breeze to install.

STANDARD SAFETY FEATURES

Supplied with an impressive list of standard safety features, the Apollo offers peace of mind with it's in-car emergency telephone, infra-red door sensors, emergency battery backup lowering system and lighting. On top of that, the Apollo has a very easy to use external manual lowering valve, should the lift car ever need to be lowered.

WATER HYDRAULICS

Providing a smooth ride, the Apollo uses a simple but effective direct acting water hydraulic drive system.

Fitted with a pump and reservoir to recycle the water, the Apollo offers continuous worry free operation whilst being environmentally friendly.

A tried and tested means of hoisting, the water hydraulic cylinders require either additional space above the lift, or a trench for lowering the cylinders below the lift's standard 80mm pit.

A variable measurement, the length of the hydraulic cylinders is reflective of the height that the lift car needs to travel (FFL to FFL). For further details, please contact one of our trained lift consultants.

LIFT TOWER

Built as a free-standing, self-supporting unit and weighing approx 350kg, the lift tower is fabricated from aluminium and comes complete with doors, door jambs, flashings, electrical wiring and hydraulic cylinders.



Depending on space and architectural needs, the lift shaft can be set up for cladding to be applied directly to it's own frame work.

To create a flush running surface between the landings, each lift is fitted with a panel between the landing doors preventing the need for any lift car doors.

LIFT CAR

Available in two styles of configuration:
 ▶ Single entry "**A Model**" with entry and exiting on the same side
 ▶ Dual entry "**B Model**" with entry at the front and exiting via the rear.

Lift cars can be individually built to the customer's requirements - up to a maximum floor space of 1.3m² or supplied in the standard size of 900mm wide x 1300mm deep x 2100mm high.



Why buy Australian Made?

- ▶ Built to Australian Standards
- ▶ Confidence in Quality
- ▶ Short lead times
- ▶ Parts readily available
- ▶ Jobs created in Australia
- ▶ Supporting Australian Economy
- ▶ Profits remain in Australia
- ▶ Ensuring skills are retained for future generations



LIFT CAR INTERIOR

Fabricated from aluminium, the frame of the lift car is lined with a series of composite panels with shadow lines. The white composite ceiling panel is fixed into place with a shadow line and chrome fixings.

Standard car features include:

- ✓ Internal controls for each levels, and emergency stop
- ✓ Stainless steel handrail
- ✓ Non-slip grey indoor outdoor carpet
- ✓ Emergency telephone recessed into a control box
- ✓ 2 x recessed down lights
- ✓ Light rays across the door entrance

LANDING DOORS

Fitted with swing action doors with a mechanical lock, adjustable self closing door closer and electrical interlock the whole assembly is part of the lift shaft.

Door styles include:

- ✓ Redicote flush door with optional glass view panel
- ✓ Pattern doors from the Hume/ Corinthian internal door range
- ✓ Metal door with optional glass view panel
- ✓ Glass door

To assist in the operation of the doors, automatic door operators or sensory operation can be fitted to the landing doors as an optional extra.

Door size for **standard** lift car: 920mm wide x 2040mm high. Lift can be supplied with 2340mm high doors.

STATIONS

Mounted to the front of the lift shaft and onto a stainless steel plate, the round stainless steel buttons are automatic in operation.

For securing the lift against unwanted users, each control is fitted with an isolating key switch. Used in conjunction with the parking facility, the lift car will position itself just above the lower landing, preventing either of the landing doors from being opened. This command can be overridden at either landing by keying the lift back on.

MACHINE CABINET

The Apollo uses a separate lift machine cabinet that creates a more compact lift shaft design and eliminates costly machine room construction.

Fabricated from metal, and powdercoated, to withstand the external elements, the cabinet is mounted at the ground level for easy access for emergency and maintenance purposes.

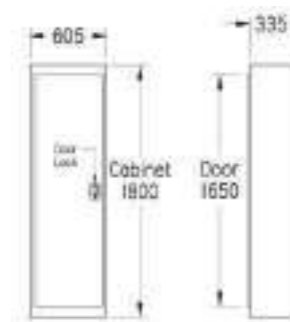

Provided with a key lockable door, the cabinet contains the hydraulic power unit, recyclable water tank, hydraulic control valves, electrical control board, emergency power supply, cabinet lighting, emergency tools and instructions.

INSTALLATION

Supplied assembled & pretested, the design of the Apollo allows for easy installation by either craning in, dismantling or manoeuvring into place.

Able to be installed within 2-3 days, the Apollo is perfect for new or existing homes as time on site is minimal.

ELECTRICAL REQUIREMENTS

The standard models all have the same economical power requirements.

- ▶ 240volt. Single Phase. 20amp RCD protected
- ▶ Active analogue telephone line

MAINTENANCE

For optimum performance, reliability and long term use, the lift should be serviced every 12 months by an approved lift technician. For all water lifts, a major service is required every 4 years.

WARRANTY

For all warranty enquiries, please check with your local Aussie Lifts dealer.

